

Installation & Operating Instructions

Note: All dimensions shown in millimetres

BMS E2500 Fixed Lug Belt Cleaner - Medium Duty

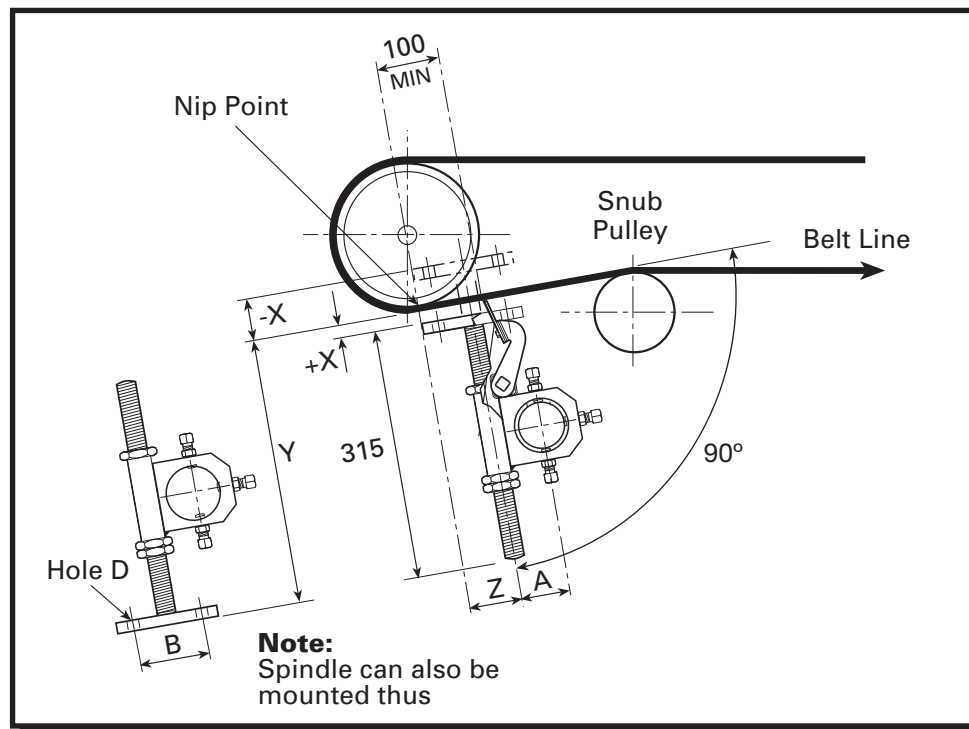

option 1. installation arrangement

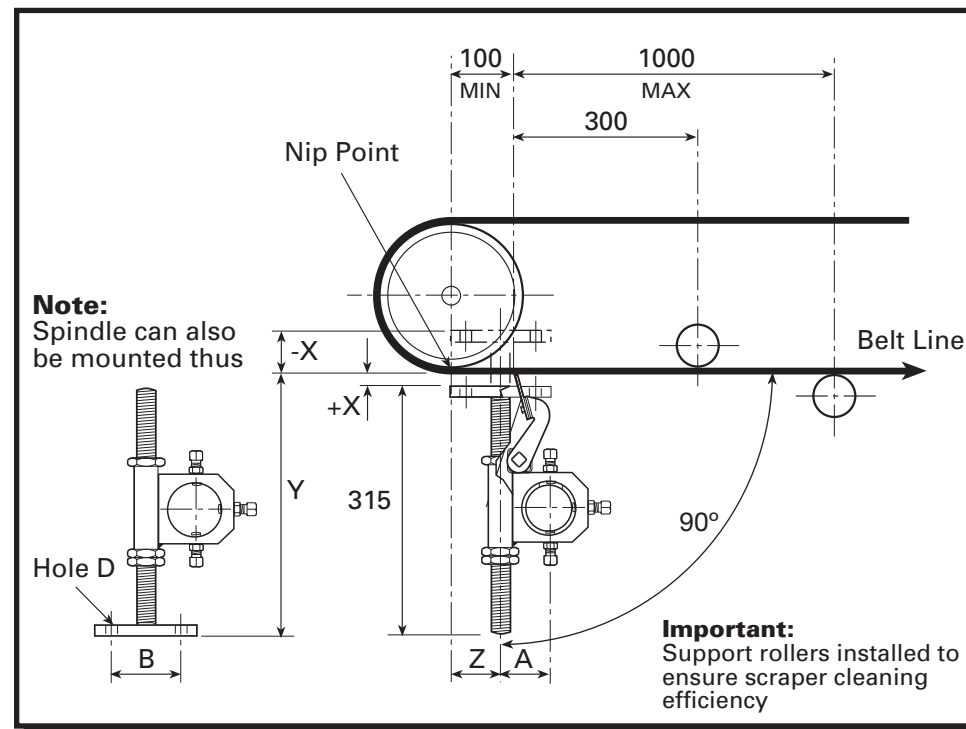

option 2. installation arrangement

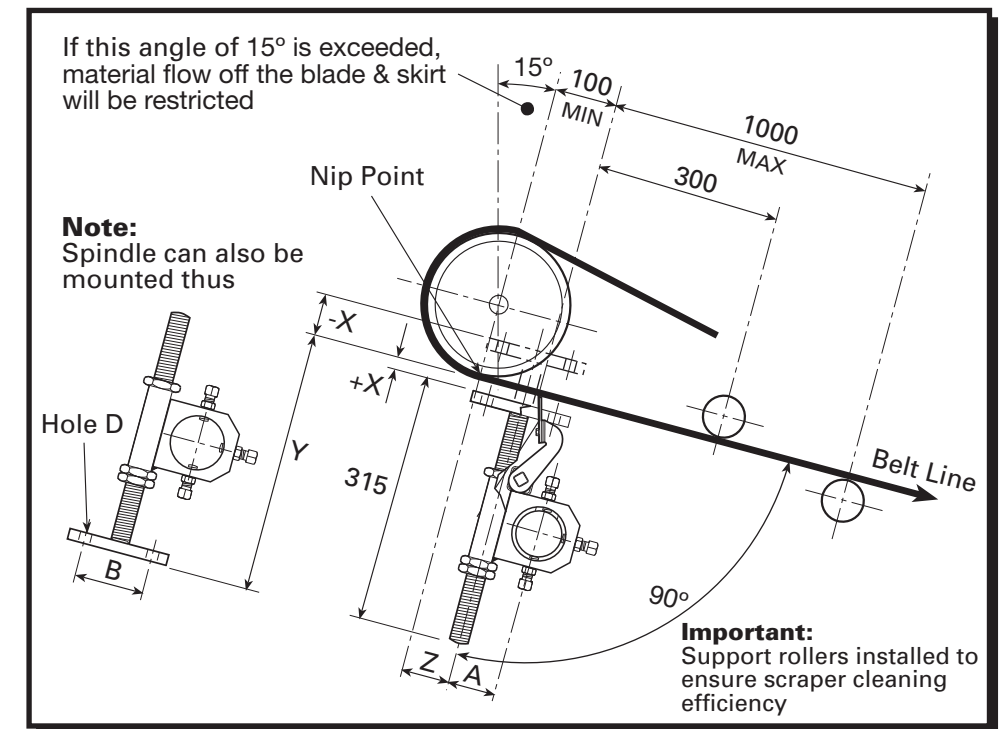

option 3. installation arrangement (when existing conveyor cannot be altered)

INSTALLATION PREPERATION

- 1) Observe the belt condition: - check any damage to the belt surface, which can influence the cleaning efficiency of the scraper.
- 2) Check mechanical or vulcanized joint for any damage and repair if necessary. Mechanical joints should be skived or at least as a minimum dressed to avoid any high points.
- 3) Check direction of the belt: remember that the **BMS** scraper must be installed **AGAINST THE DIRECTION** of the belt travel.
- 4) Check the condition of the head or snub pulley lagging.
- 5) Check if the belt reverses.
- 6) Check if the belt is supported around the installation point of the scraper and if not, install extra rollers around the installation point of the scraper to flatten out the belt in this area.

belt width	-X (min)	+X (max)	Y (min)	Y (max)	Z	A	B	hole dia 'O'	shaft dia	spindle dia	fixed lug
650	-10	100	320	430	60	75	100	18	48	M30	No.2
750	recomended		recomended								
900	110		450								

General Notes:

- 1) For maximum cleaning efficiency, correct belt tension must be maintained at all times.
- 2) Ensure spindle is mounted at 90° to the belt line.
- 3) Only the ideal scraper positions are shown, for alternatives, refer to **BMS Group**.

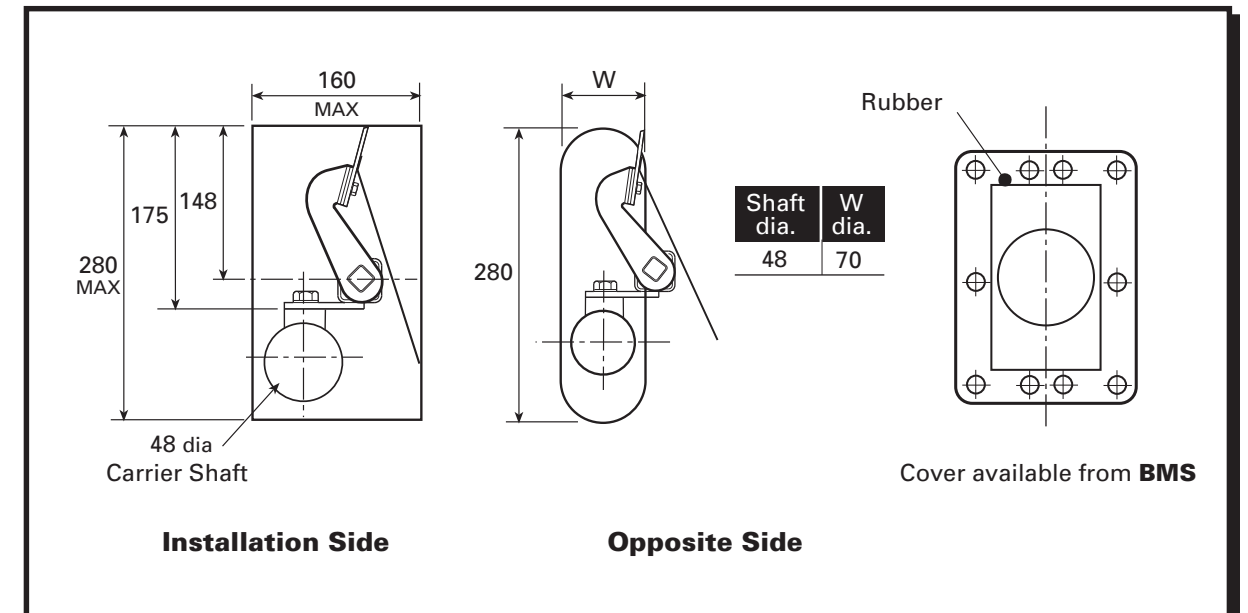

detail of chute cutouts

BMS Group continuously modify and improve its product range, therefore, information given in this leaflet may be subject to change without prior notice.



BMS Belt Cleaners Limited
(BMS Overseas Limited)
P.O. Box 19
Richmond, North Yorkshire,
England DL10 5YX

Telephone: +44 (0) 1325 483 916
Fax: +44 (0) 1325 483 746
E.mail: sales@bms-cleaners.com

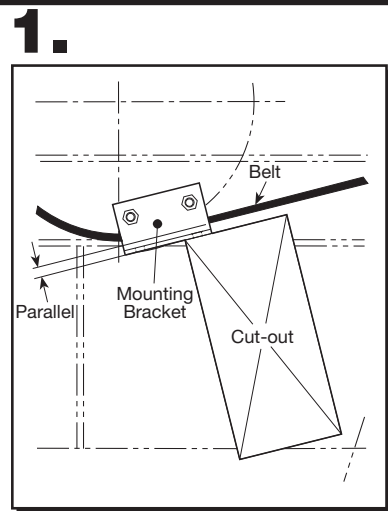

Procedure:
Install the mounting brackets and cutouts as specified in the installation drawing.

1. Prepare cutouts (both sides of chute).
2. Install brackets (both sides of chute) parallel to the conveyor belt line.

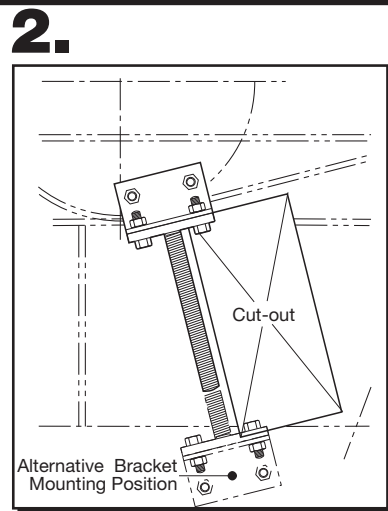

Procedure:
Attach the spindle to the prepared bracket on one side of the conveyor.

1. Bolt spindle to bracket, one side only.

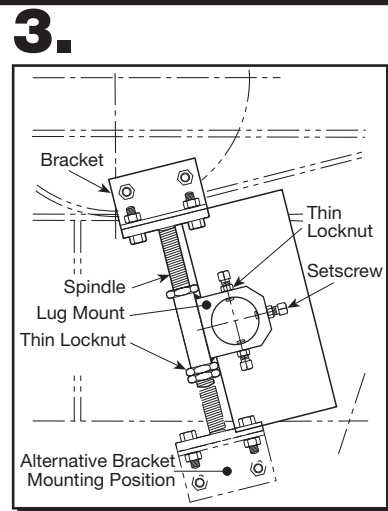

Procedure:

1. Attach one of the Spindles and one of the Lug Mounts to make an assembly.

Note:
At this stage the position of the Lug Mount on the spindle should be:

- i. if the spindle is to be installed in a "hanging position" 31.75mm of thread showing from the end of the spindle.
- or;
- ii. if the spindle is to be installed in a "standing position" 31.75mm of thread showing from the foot of the spindle.

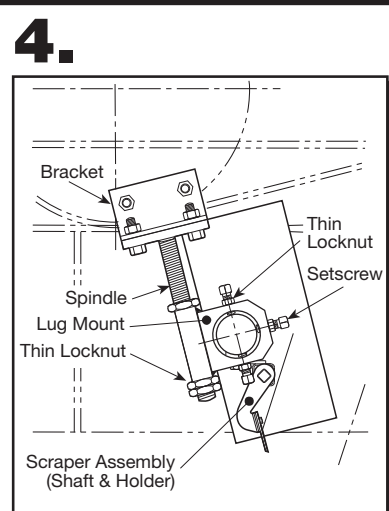

Procedure:

1. Insert the Carrier Shaft into the Lug Mount / Spindle assembly bolted to the conveyor structure.
2. Attach the other Lug Mount and Spindle to make a second assembly.
3. Slide the second assembly onto the end of the Carrier Shaft and lift the Scraper Unit (which now includes the second Lug Mount / Spindle assembly) and bolt to the conveyor structure with two M16 bolts.

Note:
Once this instruction is completed the Carrier Shaft, with Blades / Lug holders will be in a hanging position.

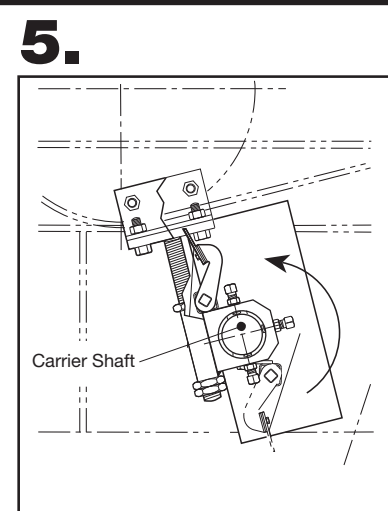

Procedure:

1. Rotate the Carrier Shaft 180° so that the Blades / Holders are in a vertical position.

Note:
If you have followed the instructions correctly, the position the blades will be a little way off touching the belt.

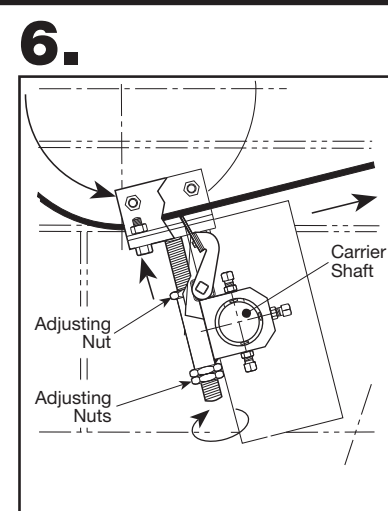

Procedure:

1. Raise the Carrier Shaft until the blades lightly touch the belt.

Note:
Adjusting the top and bottom nuts on the spindle, allows the Carrier Shaft to be moved vertically up or down.

IMPORTANT:
It is critical to the correct set up and installation of the E2500 Multi-blade Scraper that the MOUNTING BRACKETS and SCRAPER SHAFT are positioned **PARALLEL** to the belt line.

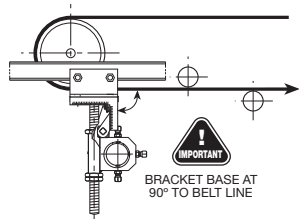

INSTALLATION OPTION 1

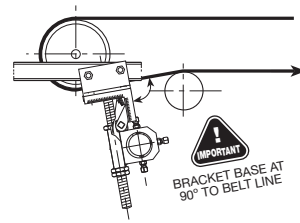

INSTALLATION OPTION 2

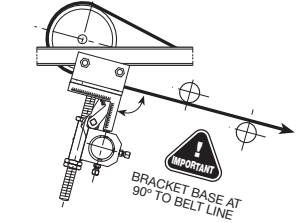

INSTALLATION OPTION 3

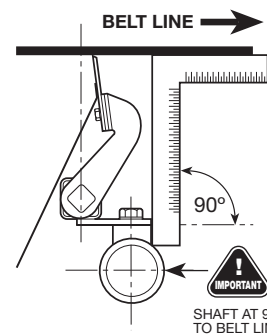

SHAFT AT 90° TO BELT LINE

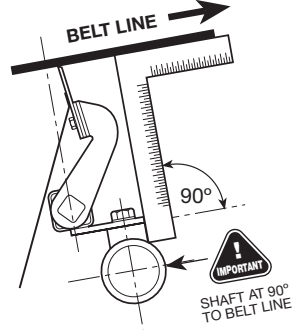

SHAFT AT 90° TO BELT LINE

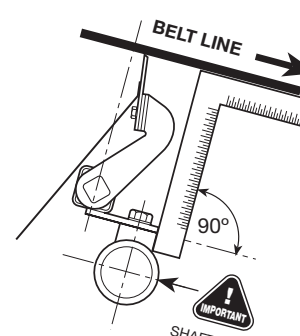

SHAFT AT 90° TO BELT LINE

START-UP OF THE BELT

Unlock the conveyor.
Perform a test run with material on the belt.
Check the belt tracking.
Installation is complete.

Note:
If cleaning efficiency is not being achieved adjust spindle nuts to raise the shaft assembly until correct cleaning efficiency is achieved.

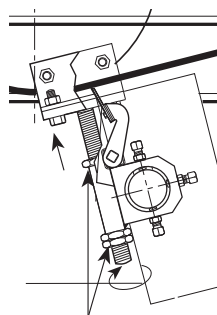

Adjusting Nuts

BLADE SETTING

In order to ensure that the BMS Multi- Bladed Scraper operates correctly, it is essential that all blades are inclined in the direction of the belt travel using the belt scraper principle like a "paint scraper"

RECOMMENDED BLADE POSITION

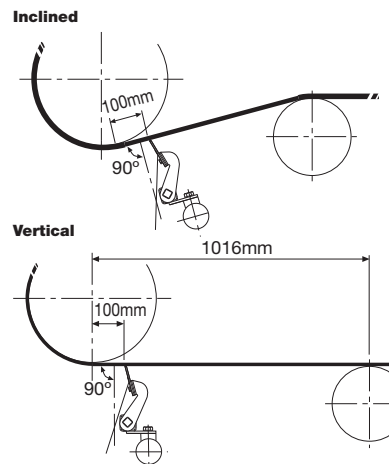

1. Spindles are installed at 90° to the belt surface.
2. The Scraper Unit is parallel to the belt.
- 3a. Inclined
The recommended blade position is 100mm minimum from the nip point (tangential point) where the belt leaves the head drum, in the cases where snub pulleys are installed.
- 3b. Vertical
The recommended blade position is 100mm minimum from the vertical centre line of the head drum.
4. In installations where there is no snub drum, the first return roller should be installed approximately 1016mm from the centre of the head drum. This will ensure that the belt is sufficiently supported.

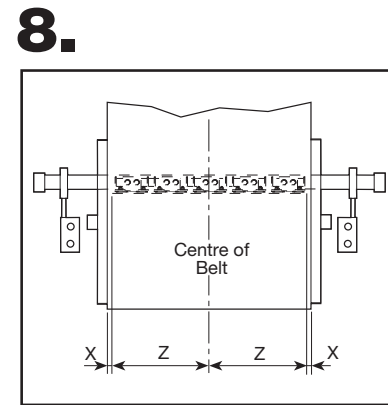

At this stage you should:

- i. Centralize the Carrier Shaft to the belt width.
- ii. Provisionally set the Carrier Shaft parallel to the belt line.
- iii. Provisionally check that the Lug Mount / Carrier Shaft is horizontal on the spindles.
- iv. Now lightly tighten the three set bolts in each of the Lug Mounts, but only sufficiently to ensure that the Carrier Shaft does not tip over.

Note:
Please do not over tighten the set bolts at this stage as the final setting of the Carrier Shaft will take place later.

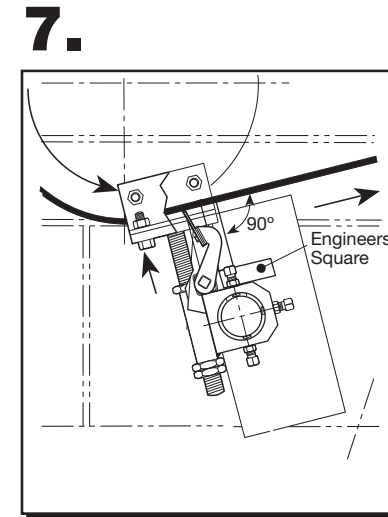

To establish that the Carrier Shaft is parallel with the belt line, use an Engineers Square to check that the 200 x 100mm flat on top of the Carrier Shaft is parallel with the belt. If not slacken off the three set bolts in each of the Lug Mounts to enable the shaft to rotate.

After satisfying yourself the Carrier Shaft is parallel with the belt line ensure that the three set bolts in each of the Lug Mounts are firmly tight.

The Scraper is now set.

